

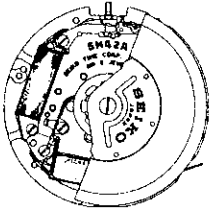

# PARTS CATALOGUE/TECHNICAL GUIDE

## Cal. 5M42A

## Cal. 5M43A

### [SPECIFICATIONS]

		Cal. No.	5M42A	5M43A
<b>Item</b>				
Movement				
			The illustrations refer to Cal. 5M42A. (x 1.0)	
Movement size	Outside diameter		ø27.6 mm	
	Casing diameter		ø27.0 mm	
	Height		4.3 mm	
Time indication			3 hands	
Driving system			Step motor (Load compensated driving pulse type)	
Additional mechanism			<ul style="list-style-type: none"> <li>• Automatic generating system</li> <li>• Power reserve indicator</li> <li>• Overcharge prevention function</li> <li>• Electronic circuit reset switch</li> <li>• Train wheel setting device</li> <li>• Date calendar</li> <li>• Day calendar (for Cal. 5M43A only)</li> <li>• Instant setting device for date calendar</li> <li>• Instant setting device for day calendar (for Cal. 5M43A only)</li> </ul>	
Loss/gain			Monthly rate at normal temperature range: less than 15 seconds	
Regulation system			Nil	
Measuring gate by quartz tester			Use 10-second gate.	
Power supply	Power generator		Automatic generating system	
	Capacitor		Polyacene lithium condenser	
Operating voltage range			Capacitor voltage: 0.5 ~ 2.3V	
Duration of charge			From 1.55V to stoppage: Approx. 168 hours	
Jewels			6 jewels	

# PARTS CATALOGUE

Cal. 5M42A, 5M43A

Disassembling procedures Figs. :

① → ⑤②

Reassembling procedures Figs. :

⑤② → ①

Lubricating: Types of oil

 Moebius A



 SEIKO Watch Oil S-6

Oil quantity

 Normal quantity

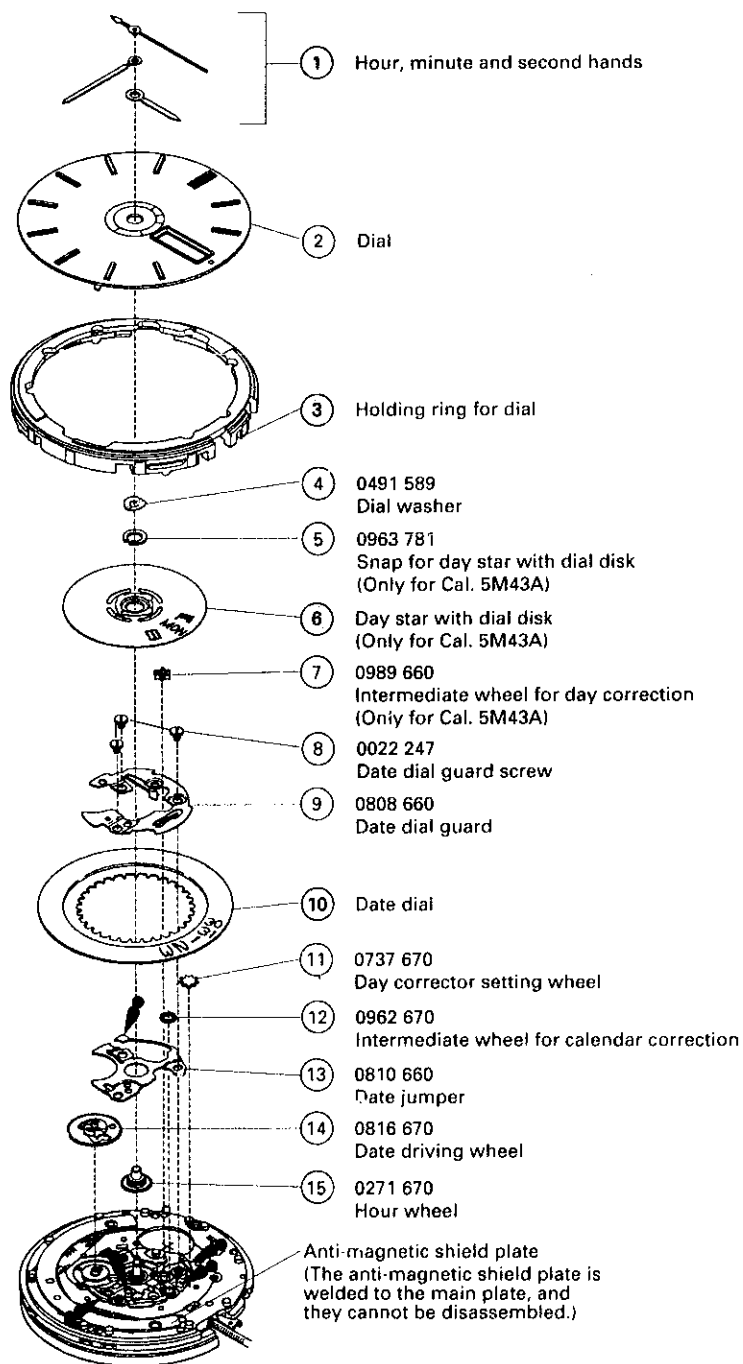
Ex.: Cal. 5M43A



	0022 247	
	• Date dial guard screw	(3 pcs.)
	• Capacitor clamp screw	(2 pcs.)
	• Circuit block cover screw	(2 pcs.)
	• Oscillating weight bridge screw	(2 pcs.)
	• Coil block screw	(1 pc.)
• Train wheel bridge screw	(1 pc.)	
	0022 490	
	• Oscillating weight screw	(1 pc.)

 Please see the remarks on the following pages.

# PARTS CATALOGUE

Cal. 5M42A, 5M43A

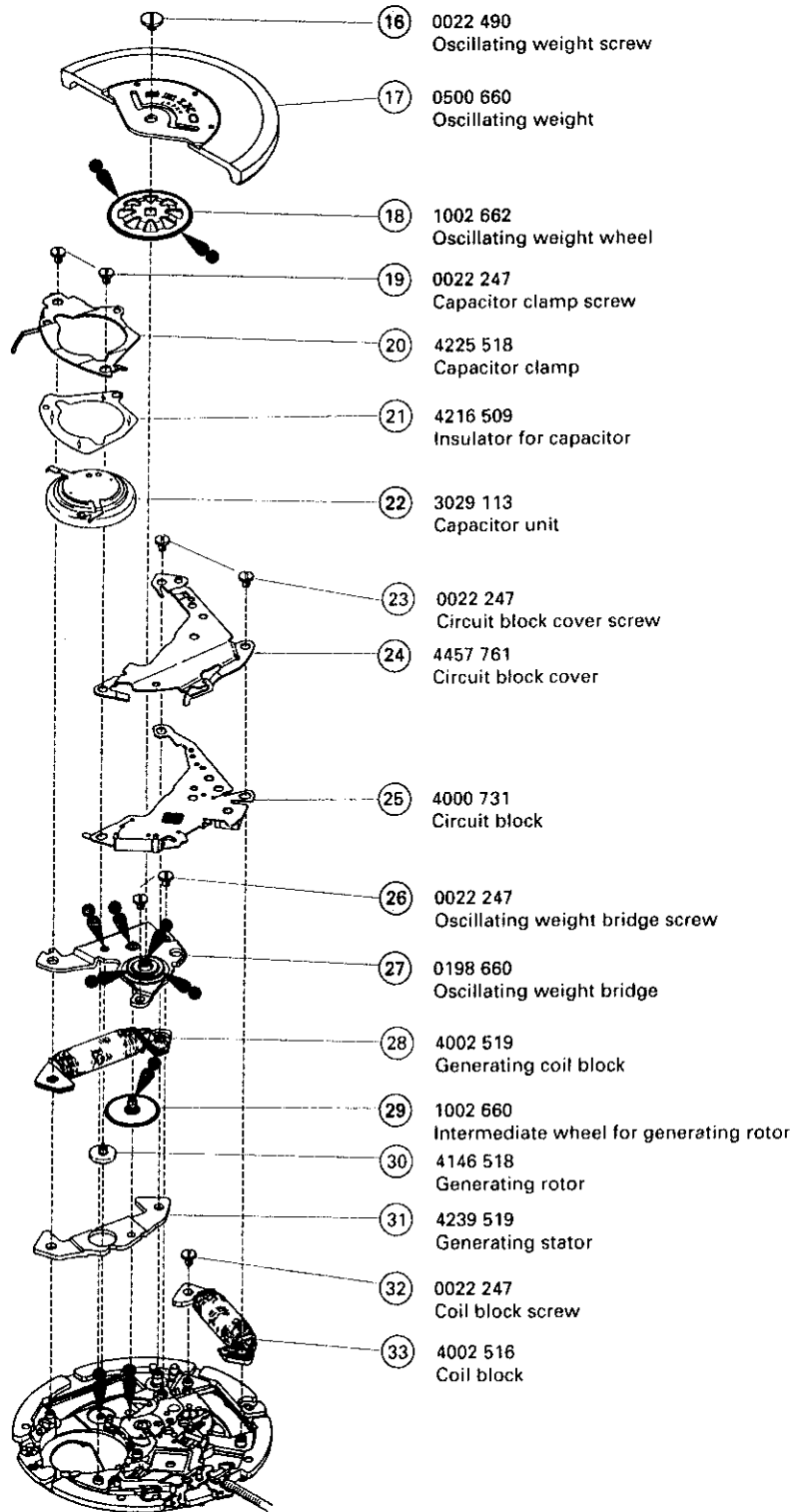

○ ⇒ Please see the remarks on the following pages.

# PARTS CATALOGUE

Cal. 5M42A, 5M43A

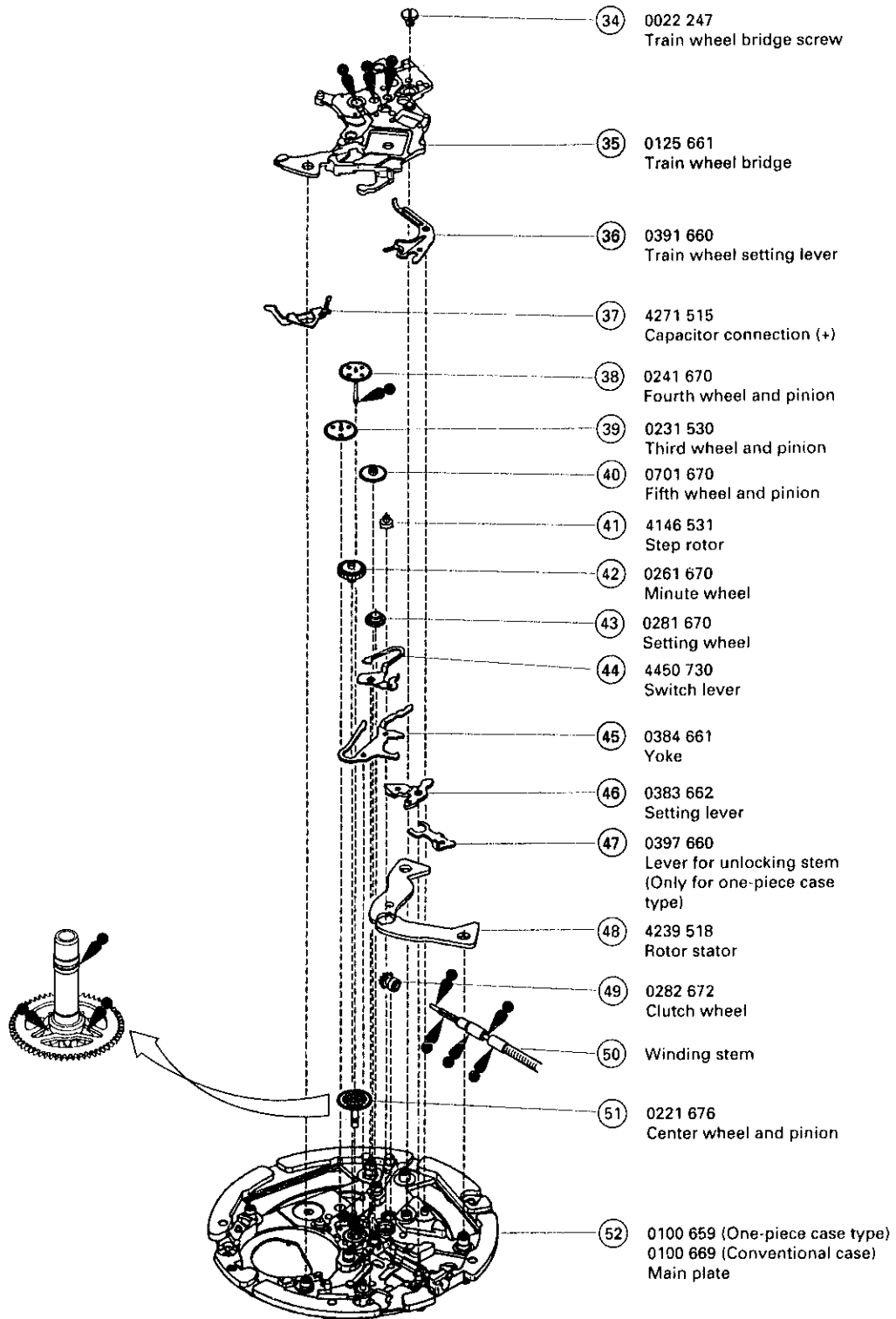

○ ⇒ Please see the remarks on the following pages.

**Remarks:**

③ Holding ring for dial

The type of holding ring for dial is determined based on the design of cases. Check the case number and refer to "SEIKO Casing Parts Catalogue" to choose a corresponding holding ring for dial.

⑥ Day star with dial disk (Only for Cal. 5M43A)

Part code	Language	Position of crown and calendar frame	Color of figure	Color of background
0150 661	English ↔ Spanish	3 o'clock	Black	White

The type of day star with dial disk is determined based on the design of cases. If any other type of day star with dial disk is required, please specify the number inscribed on the disk.

⑩ Date dial

Cal. No.	Part code	Position of crown and calendar frame	Color of figure	Color of background
5M42A	0878 729	3 o'clock	Black	White
5M43A	0878 675	3 o'clock	Black	White

The type of date dial is determined based on the design of cases. Check the case number and refer to "SEIKO Casing Parts Catalogue" to choose a corresponding date dial.

- The explanation here is only for the particular points of Cal. 5M42A and 5M43A.
- For the repairing, checking and measuring procedures, refer to the "TECHNICAL GUIDE, GENERAL INSTRUCTIONS".

## I. STRUCTURE OF THE CIRCUIT BLOCK

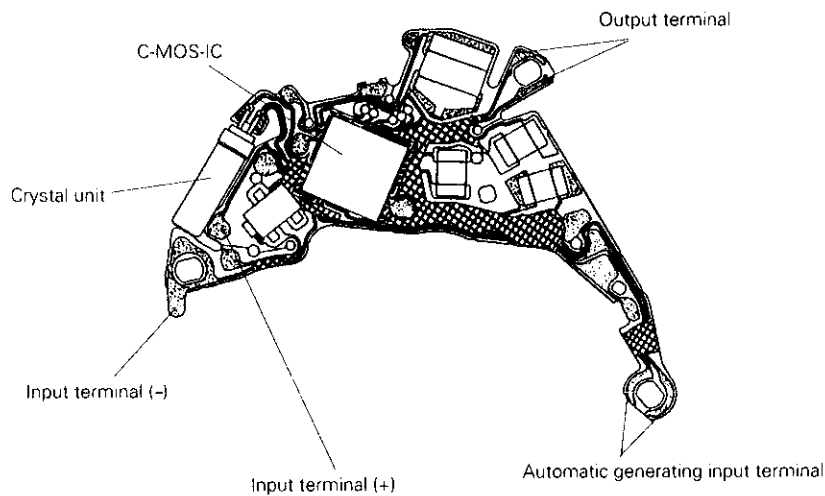

## II. REMARKS ON DISASSEMBLING AND REASSEMBLING

① Hands

### • How to install

Place the movement directly on the riveting plate shown in the illustration with the oscillating weight side down, so that the oscillating weight screw is not damaged. Then, press in the hands.

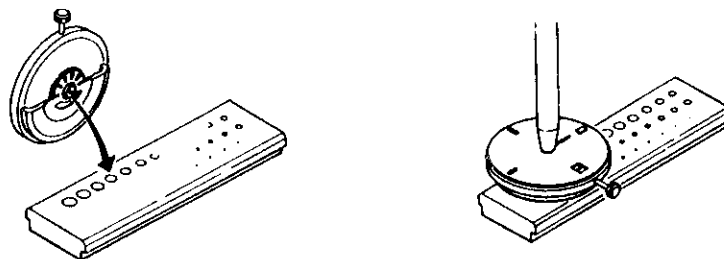

## ③ Holding ring for dial

If the watch is of the one-piece case type, the movement is fixed to the case in such a manner that the four hooking portions of the holding ring for dial catch the case.

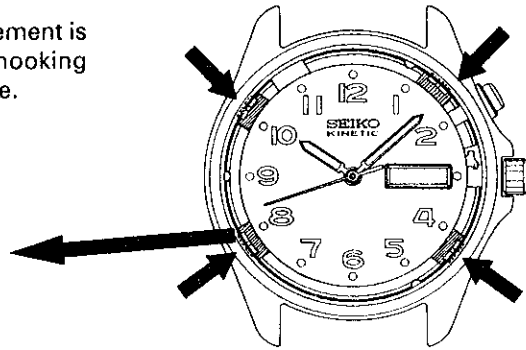
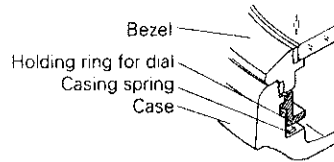

### • How to remove

- 1) While pushing the lever for unlocking stem with tweezers, pull out the winding stem.

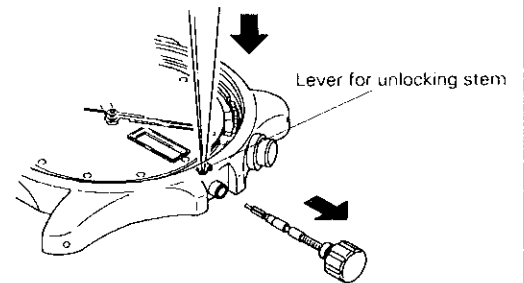

- 2) Push the protrusions of the four hooking portions toward the center of the dial with a screwdriver as shown in the illustration to release them from the case.

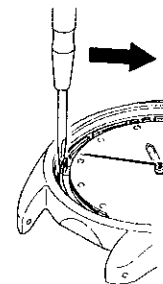

- 3) Insert the tip of tweezers into each of the grooves of the holding ring for dial positioned at 1, 5 and 9 o'clock sides, and pry the ring up to remove the movement.

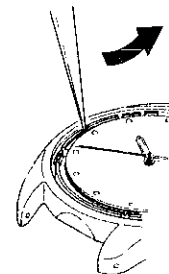

**Note:** Two eccentric posts are used to fix the dial to the main plate. To remove the dial, loosen them.

### • How to install

Set the movement level into the case, and push the hooking portions of the holding ring for dial with a screwdriver until they catch the case.

**Note:** Check that each of the four hooking portions catches the case securely, and then, tighten the eccentric posts to fix the dial.

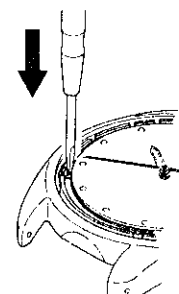

## 16 Oscillating weight screw

Tighten the oscillating weight screw very firmly, applying more force than usual.

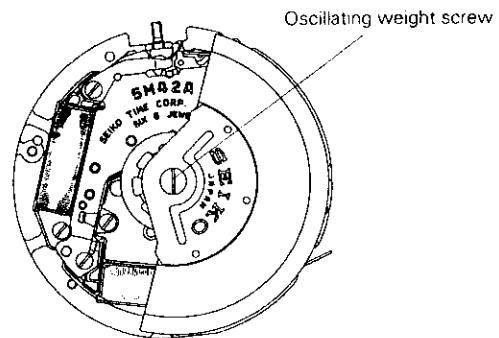

## 22 Capacitor unit

- Though the capacitor unit for Cal. 5M4 Series is of a completely different type than that for Cal. 5M2 Series, they have a close resemblance in shape. To prevent confusion between them, the capacitor unit for Cal. 5M4 Series has two holes for discrimination on its lead terminal portion. When replacing the capacitor unit, check for the holes to make sure you are using the proper one.
- Be sure to observe the correct polarity of the capacitor unit. The lead terminal side is the (-) side as shown in the illustration.
- To install the capacitor unit, set the "A" portion to the hole of the main plate, and then push the "B" portion so that it is fixed in position.

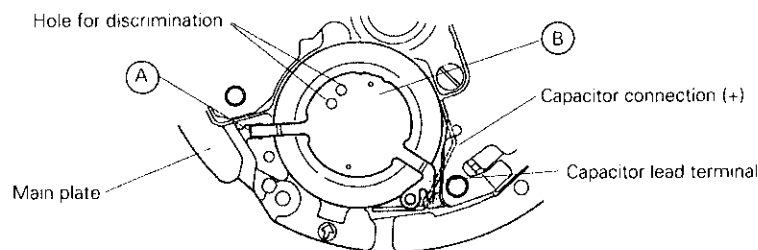

**Note:** Handle the capacitor unit with care so as not to short-circuit its (+) and (-) terminals.

## 24 Circuit block cover

The circuit block cover we are supplying has no calibre number nor numeral printed on it for discriminating the hand installation height.

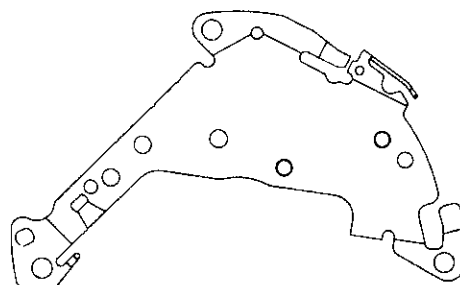



26 Oscillating weight bridge screw

27 Oscillating weight bridge

- Before tightening the oscillating weight bridge screw, check that the upper pivot of the generating rotor is inserted properly.
- Be sure to lubricate the upper and lower pivots of the generating rotor and intermediate wheel for generating rotor in the quantity specified in the illustration.
- Be sure to lubricate the ball-bearing of the oscillating weight bridge as shown in the illustration.

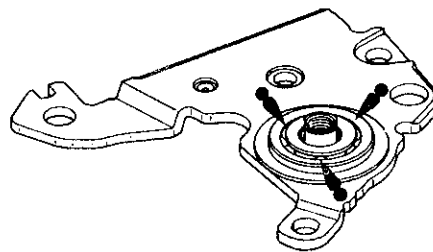
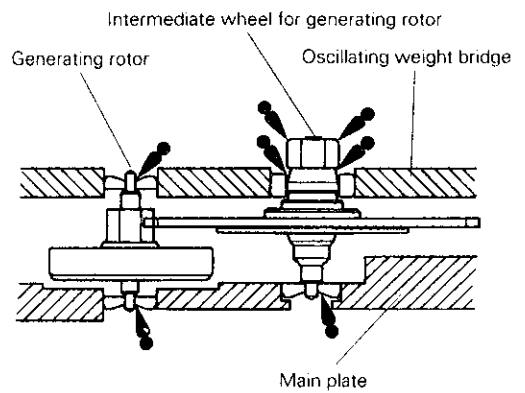

29 Intermediate wheel for generating rotor

• Lubricating

Refer to the illustration at right.

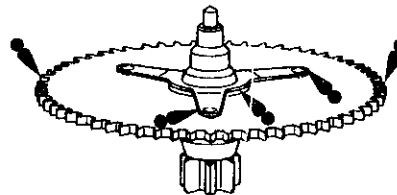

35 Train wheel bridge

• Setting position

Refer to the illustrations below to check where to install the respective wheels.

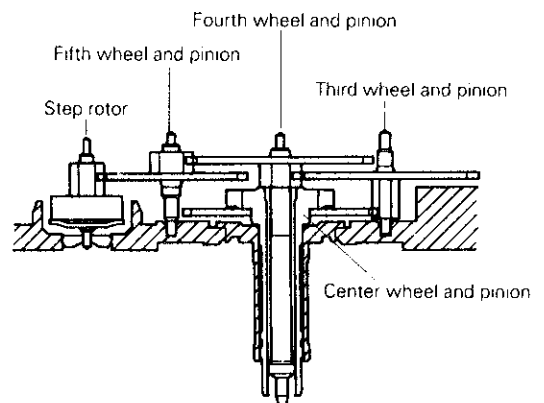
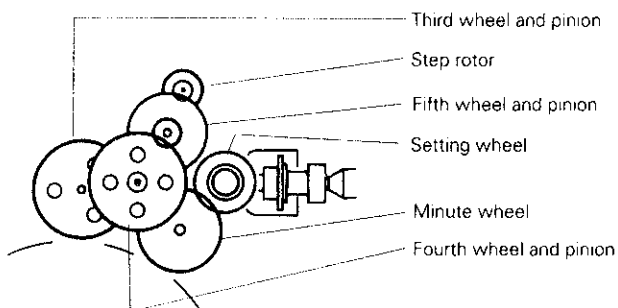

- ③⑥ Train wheel setting lever
- ④④ Switch lever
- ④⑤ Yoke
- ④⑥ Setting lever
- ④⑦ Lever for unlocking stem

- **Setting position and lubricating**

Refer to the illustration at right.

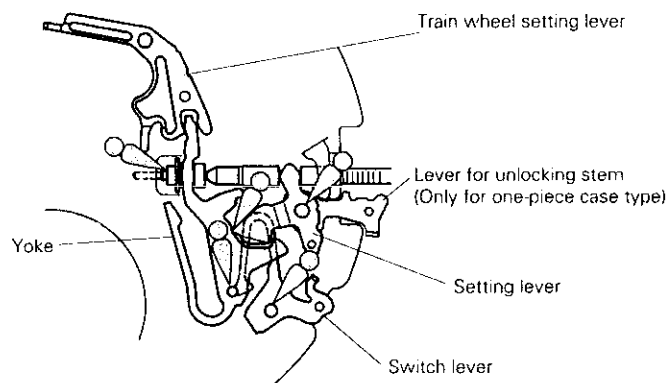

### III. VALUE CHECKING AND ADJUSTMENT

- **Coil block resistance**

1.7K $\Omega$  ~ 2.1K $\Omega$

- **Generating coil block resistance**

280 $\Omega$  ~ 380 $\Omega$

- **Current consumption**

For the whole movement	:	Less than 0.7 $\mu$ A (with voltage supplied from a battery)
For the circuit block alone	:	Less than 0.4 $\mu$ A (with voltage supplied from a battery)

- **Measuring the current consumption for the whole movement**

- 1) Connect the tester as shown in the illustration.

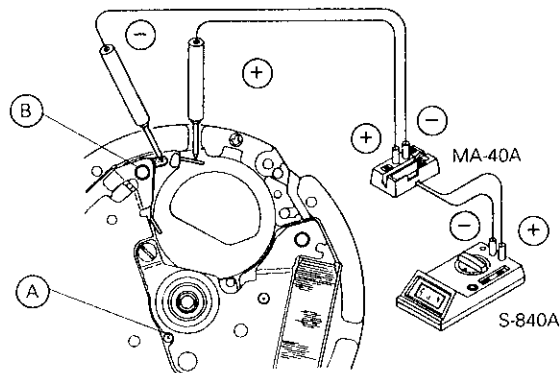

- 2) Start the measurement 30 to 40 seconds after connecting the tester, checking that a stable measurement is obtained.
- 3) When measuring, look through the upper hole jewel for step rotor (A) in the illustration), to check that the step rotor is rotating at one-second intervals.

**Note:** If a stable measurement is not obtained for the current consumption, temporarily tighten the capacitor clamp screws at the hole (B) and then measure the current consumption again.

- **Measuring the current consumption for the circuit block alone**

Connect the tester to the input terminals (+) and (-) of the circuit block, and wait for 30 to 40 seconds before starting measurement.

**Remarks:**

When the current consumption exceeds the standard value for the whole movement but is within the standard value range for the circuit block alone, the watch is generating a driving pulse to compensate for the heavy load that may be applied to the gear train, etc. In this case, overhaul and clean the movement parts and then measure current consumption for the whole movement again.

- **Checking the automatic generating system**

- 1) Apply the probes of the tester to the capacitor unit as shown in the illustration to measure the voltage.

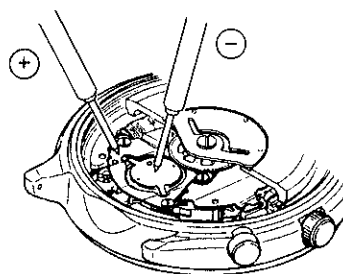

- 2) Close the case back temporarily, and swing the watch from side to side approximately 100 times rhythmically (at a rate of 2 to 3 times a second) with a snap of the wrist as shown in the illustration.

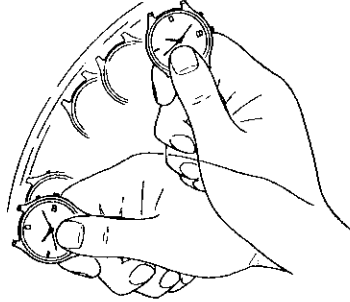

- 3) Remove the case back, and measure the voltage of the capacitor unit in the same manner as in step 1) above.
- 4) If the voltage obtained has increased more than 0.1V from the initial voltage assuming that the initial voltage is within the range between 0.5V and 1.0V, the automatic generating system is operating normally.

\* To recheck the automatic generating system, leave the watch untouched for more than 5 minutes, and then repeat steps 1) to 3) above.

**Recharging information:** Number of swings required and the duration of charge until the watch stops operating

Cal. 5M Series watches are equipped with a power reserve indicator. The current power reserve can be checked using the second hand at the press of the button at the 2 o'clock position.

(The table below assumes that the initial voltage of the capacitor unit is 0.5V.)

Number of swings	Duration of charge	Quick movement of the second hand when the power reserve indicator function is activated
100	Approx. 6 hours	5 seconds
400	Approx. 2 days	10 seconds
700	Approx. 4 days	20 seconds
1,100	Approx. 7 days	30 seconds

**Note:** If the voltage of the capacitor unit fluctuates, the movement of the second hand may not indicate the actual power reserve. To check the relationship between the number of swings and the duration of charge, use the power reserve indicator more than one hour after swinging the watch the number of times specified in the above table, and then check if the watch keeps operating for the indicated duration of charge.

Cal. 5M42A and 5M43A are so designed that the capacitor can be charged up to 2.2V. Even if the watch is fully charged, however, the power reserve indicator can only indicate that the capacitor voltage is more than 1.55V, which corresponds to 7 days of duration of charge, with the second hand showing 30 seconds of quick movement. The actual duration of charge is more than 7 days when the watch is fully charged.